

MKE4 Engine Control Unit



Applications: Engine control unit up to 4 cilinder engines
- militar connector equiped .

Engine configuration

Fuel injection	sequential for up to 4 cil. , semisequential for up to 8 cil.
Injection phase	customizable variable timing
Ignition	integral for up to 4 cil. , lost spark for up to 8 cil.
Ignition coils	inductive with variable charge timing
Drive by Wire	version HD for electronic throttle control
Intake Air system	natural / forced
Signal Configurations	Many available , other on request
Engine Speed	up to 22000 rpm

Mechanical

Case	Water proff , Alluminium CNC Machined
Maximum size	40.5 x 116 x 134.5 mm
Weigth	530 g
Temperature range	-25 , 85 Celsius
Relative humidity range	0 , 100 %

Electrical

Power supply (protected from accidental inversion)	8 , 22 Volt
Current (min.).....	100 mA

Digital Core

CPU	Mitsubishi 16 MIPS
Flash EEPROM memory for code	256 kByte
EEPROM memory for data.....	16 kByte

Connectors (MIL Specifics -C26482)

ECU side - 41 pole	SOURIAU 851 02E 20-41 P 50
Wiring Harness side - 41 pole (Crimp Version).....	SOURIAU 851 06RT 20-41 S 50
Wiring Harness side - 41 pole (Solder Version).....	SOURIAU 851 06T 20-41 S 50

Internal Inputs

Analog , Sensor power supply voltage (for diagnostic poupose).....	1
Analog , temperature sensor.....	1

...

External Inputs

Analog , 0 – 5 volt (typical use TPS , APS , MAP , AUX , FUEL Pressure)	4
Analog , external NTC (typical use WTS , ATS , OIL Temp. , FUEL Temp.).....	2
Analog , ECU power supply voltage.....	1
Analog , 0 – 1 Volt oxigen sensor.....	1
Digital , hardware interrupt with pull-up (typical use Gear Change , AUX).....	1
Pickup / Speed / Frequency , (hall effect / inductive differential input)	2
Multiplexed (with CAN BUS)	up to 2048

Notes : All analog input with 10 bit ADC and internal digital antialiasing and low pass filter .
All input are protected for short circuit to ground and to power supply .
Optional Wide Band Lambda Sensor from CAN BUS (available Mectronik interface for Bosch LSU)

Outputs

Injector power stages , (8 A each , max 18 A total).....	4
Ignition power stages , (12 A each , max 24 A total).....	4
PWM power stages , (3 A each).....	2
H-Bridge power stages , (8 A , only version HD)	1
On/Off power stages , (3 x 0.5 A)	3
Sensor Power Supply , (100 mA)	1
Multiplexed (with CAN BUS)	up to 2048

Notes : Ignition with digital stages on request .
Short circuit protection for On/Off power stages , sensor power supply and CAN BUS lines .

Communications

Can Bus (for datalog , tuning , in/out expansion)	1 x BOSCH 2.0 b
Serial (current loop)	1 x RS232

Fuel Injection Management

For normal aspirated engines , the ECU use engine speed and TPS as main parameters . For forced aspirated engines , the ECU use engine speed and intake air pressure as main parameters . The injection may be corrected as a function of :

- NTC inputs
- Analog inputs
- Crank revolution from start
- Individual cilinder (up to 4 cilinders)
- Power supply voltage
- Throttle transient
- Other paramters from CAN BUS (on request)
- Partial / complete CutOff may be actuated during strategies

The start of injection may be setup in function of engine speed (and/or other parameters on request) for better engine tuning in all conditions .

Ignition Management

For ignition , the ECU use the same main parameters used for Injection . The ignition angle ma be corrected as a function of :

- NTC inputs
- Analog inputs
- Individual cilinder
- Other paramters from CAN BUS (on request)
- Variations may be actuated as function of strategies parameters
- Partial / complete CutOff may be actuated during strategies

The coil charge may be setup through charge time as function of power supply voltage .

Output Controls

Using the 2 PWM power stages , it's possible to manage actuators for open or closed loop digital controls . Typical applications may be : turbo pressure (waste-gate) control , engine idle speed , variable cam phase timing , variable length inlet trumpet , nitrous injection , water injection , alternator control .

Using the 3 On/Off power stages , it's possible to setup sommands for many simple actuators , typical uses may be : fuel pump relay , rpm dash board , diagnostic lighth , shift gear lighth , fan cooler relay , allarms .

Drive by Wire (electronic throttle control)

The version HD have H-Bridge power stage for optimum electronic throttle control .The drive by wire feature , is implemented inside the engine management system , in this way is possible to have better error detection , with better recovery system (including fuel cutoff and rpm limiter) . The ECU will signal also all possible errors on pedal and throttle body (input and output) . The driver by wire is used also for special advanced features (gear change cut and kickup , launch control and traction control) .

Variable Cam Timing

Closed loop CAM position (ex. VANOS , VVT ...) is managed at very hi speed and precision . Control is customizable PID algorithm , that can be adapted for different system requirements . Actuator is drive with PWM output (from 1 to 30000 hz) .

Multiplexed network with CAN BUS

The ECU is ready to share variables with external devices using the CAN BUS network . The speed rate may be setup up to 1 Mbit . Standard and Extended message format are possible . Typical applications for CAN BUS line are : connection with tuning tools , datalog , dash board , datashare , expansion with external multifunction in/out interface .

FirmWare

The firmware is stored inside the CPU on Flash memory . It's application specific , so is designed for better optimization for used functions/strategies . The firmware can be update from external using serial interface . Custom functions/strategies can be developed on request , for application specific and exclusive version . We can also offer custom options for interfacing to third part devices (data acquisition , dash board , other veicle ECU) , using CAN BUS , RS232 or multi function in/out .

Options and Tuning Tools

Some hardware options can be requested for specific applications (Ex : management of digital coils) . Custom firmware application support .

Basic tuning tool is the Mectronik CALMAN software , it's a full programmable Windows 32 bit multitasking software . Both serial RS232 (USB-232 interface avaiable) and CAN BUS (many different interfaces) are supported . With the same software it's possible to work with all other MK series Mectronik products .

Stand alone consolle (with potentiometers , encoders , buttons and LCD) , for easy tuning , under developement .

Dimensional Drawing

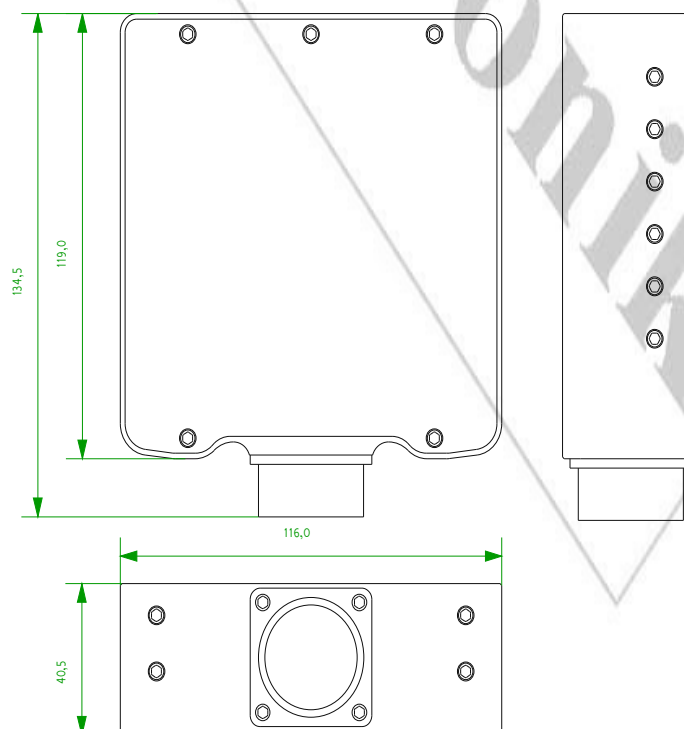

Per eventuali dettagli o informazioni contattare :

Tutti i valori riferiti alle condizioni standard. (20° C, 100 KPa)
Versione Hardware prodotto : 1.2.0

MecTronik S.r.l. - Via dell'artigianato, 5 - 37053 - Cerea (VR)

Tel./Fax : +39-(0)442-329200 (lines r.a.)

<http://www.mectronik.com>

info@mectronik.com